

A	B	C	D	
1	S162-006	494	176	2/2
2	S162-016	494	200	2/2
3	S162-112	477	371	1/2
4	S162-113	477	371	1/2
5	S162-203	520	397	1/2
6	S162-404	488	60	1/2
7	S162-405	488	60	1/2
8	S162-408	488	60	1/2
9	S162-904	461	355	1/2
10	S162-909	442	513	1/2
11	ZS3-509	350	120	1/2
12	ZS3-510	350	120	1/2
13	ZS3-5506	439	120	1/2

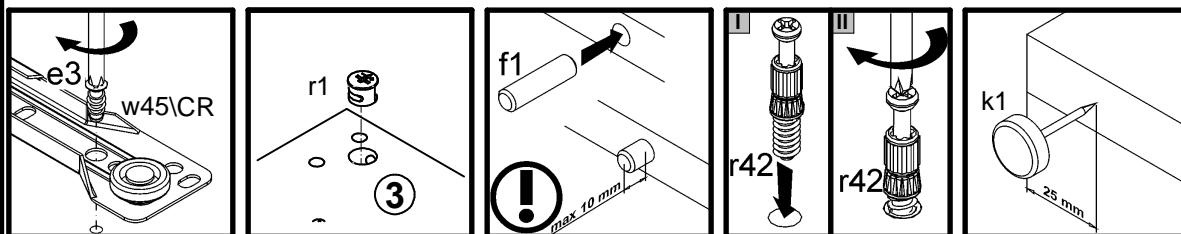

2

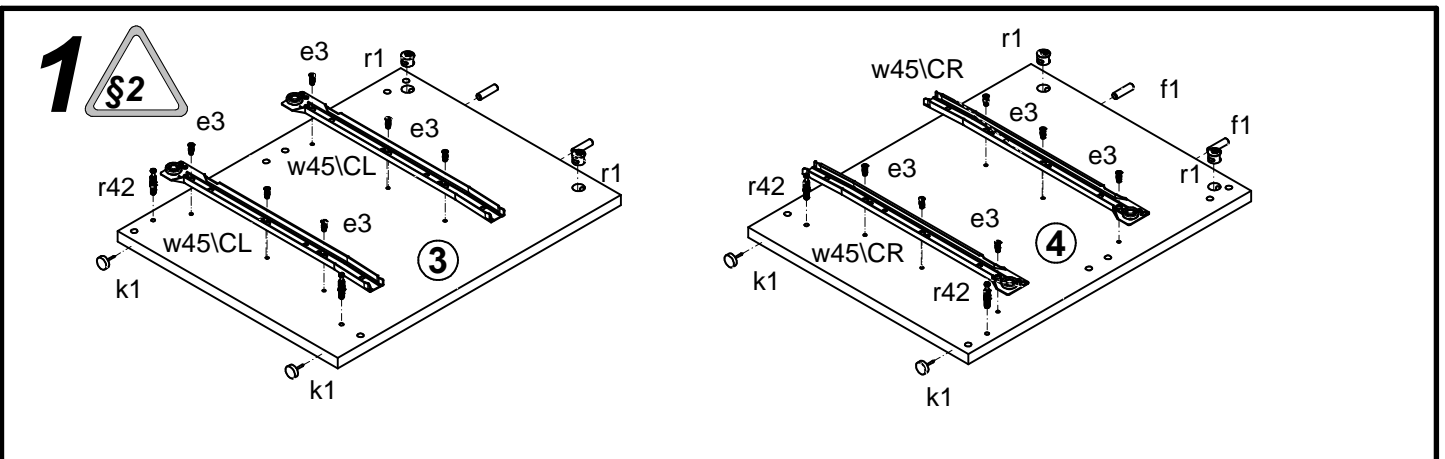
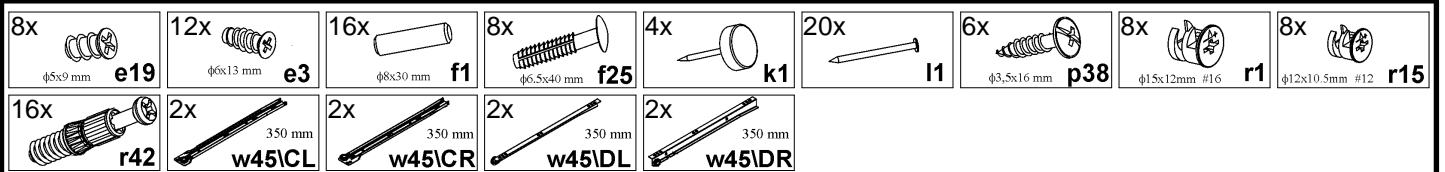
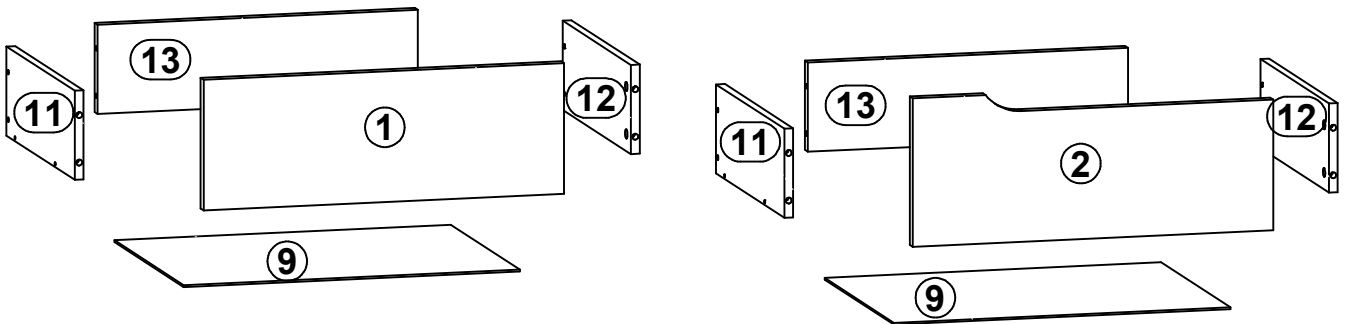
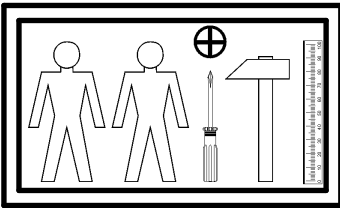
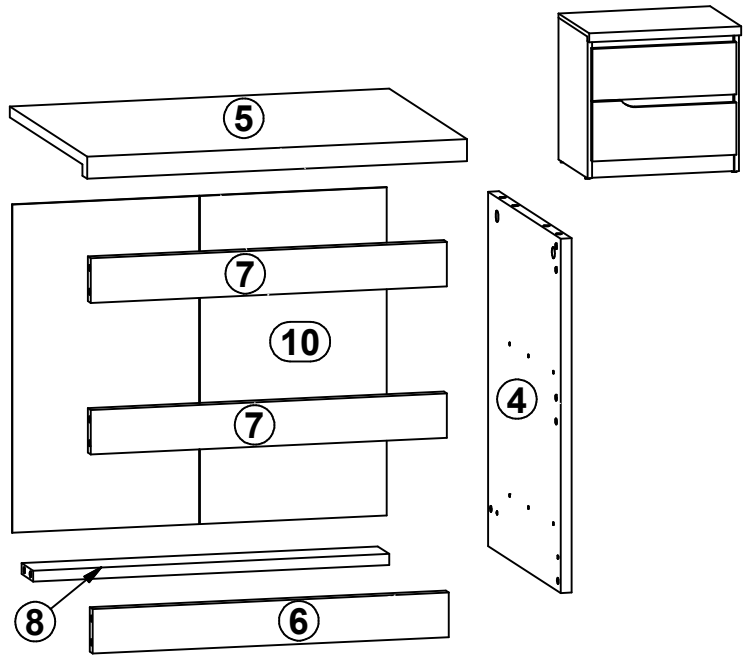
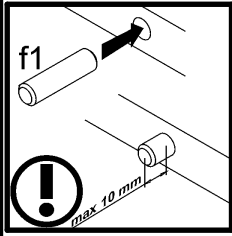
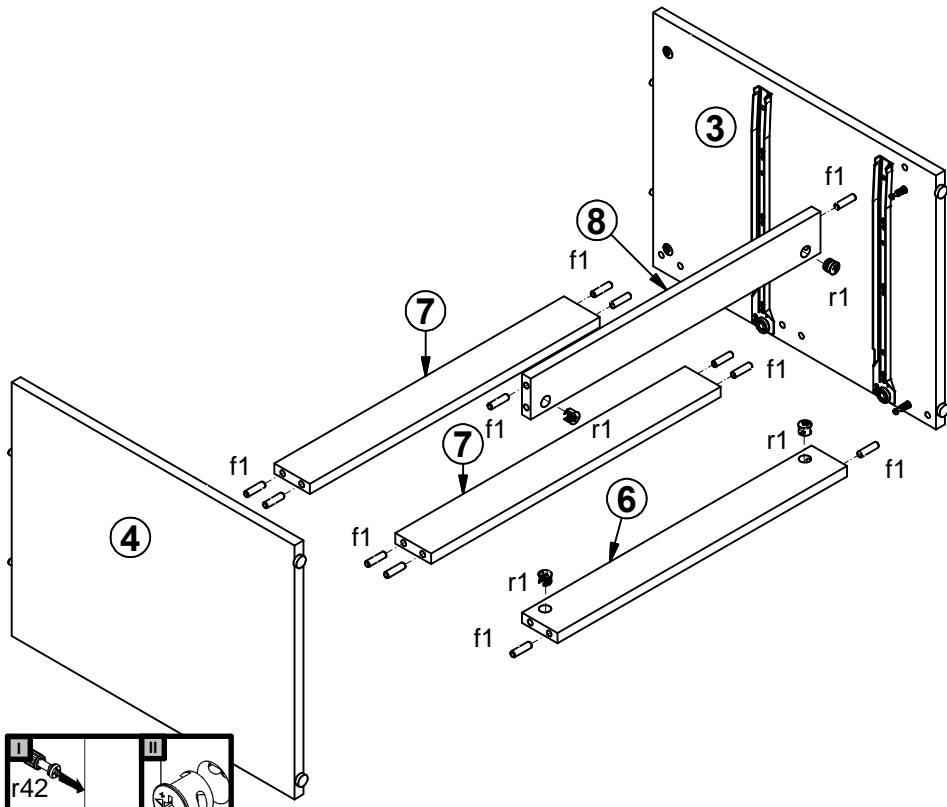

3

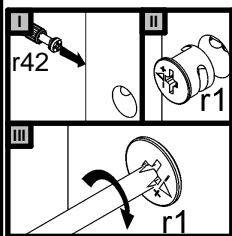
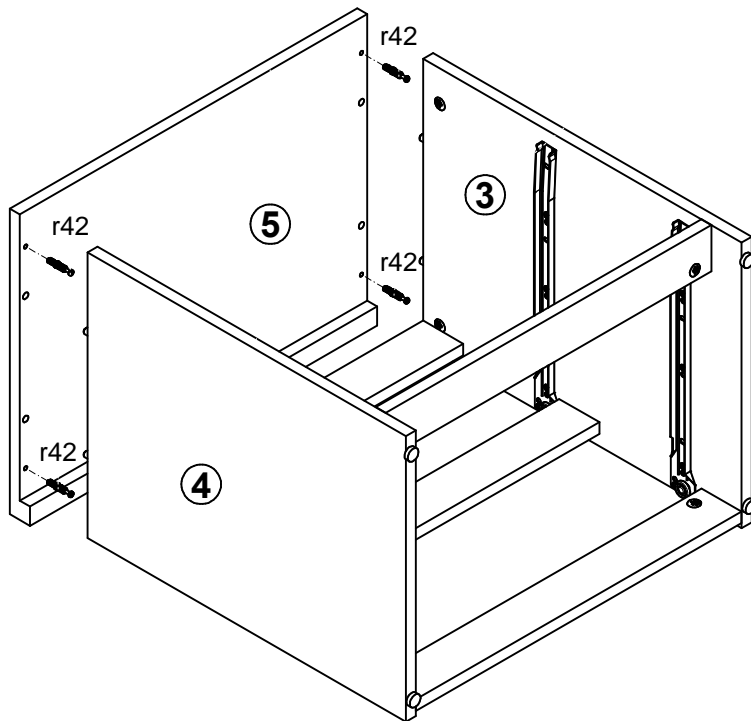

4

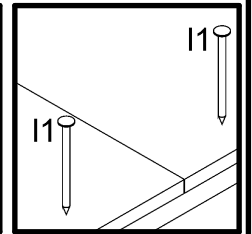
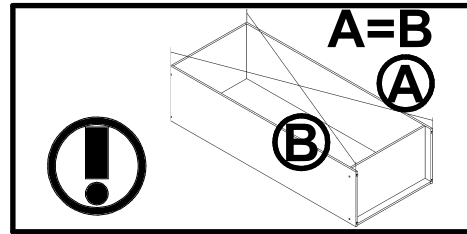
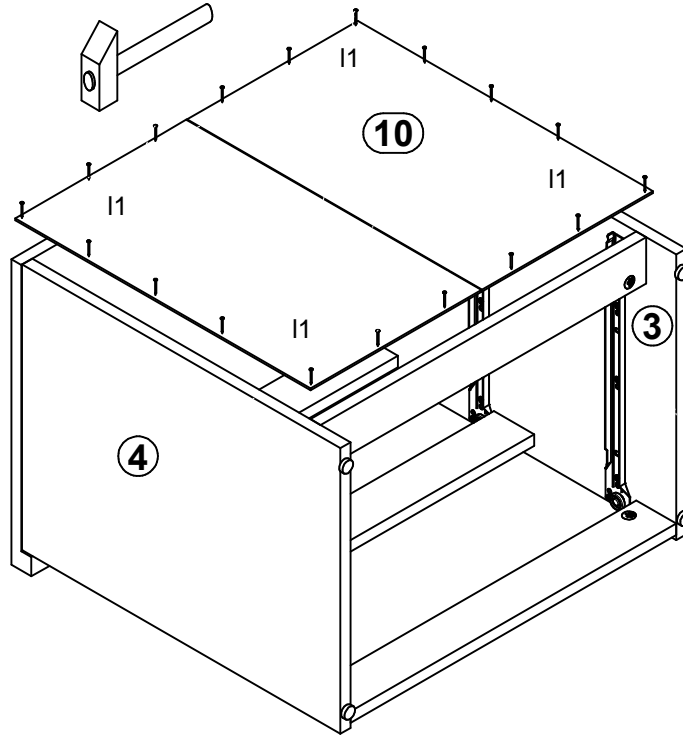

5

