

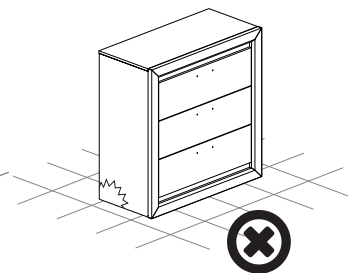

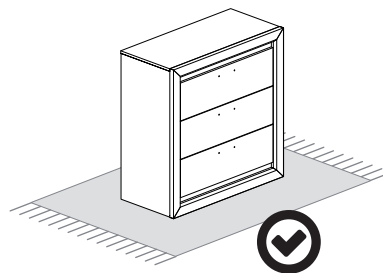

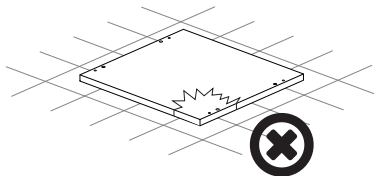

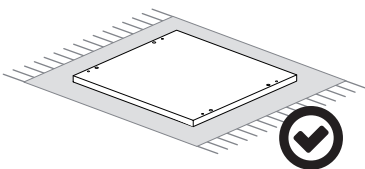

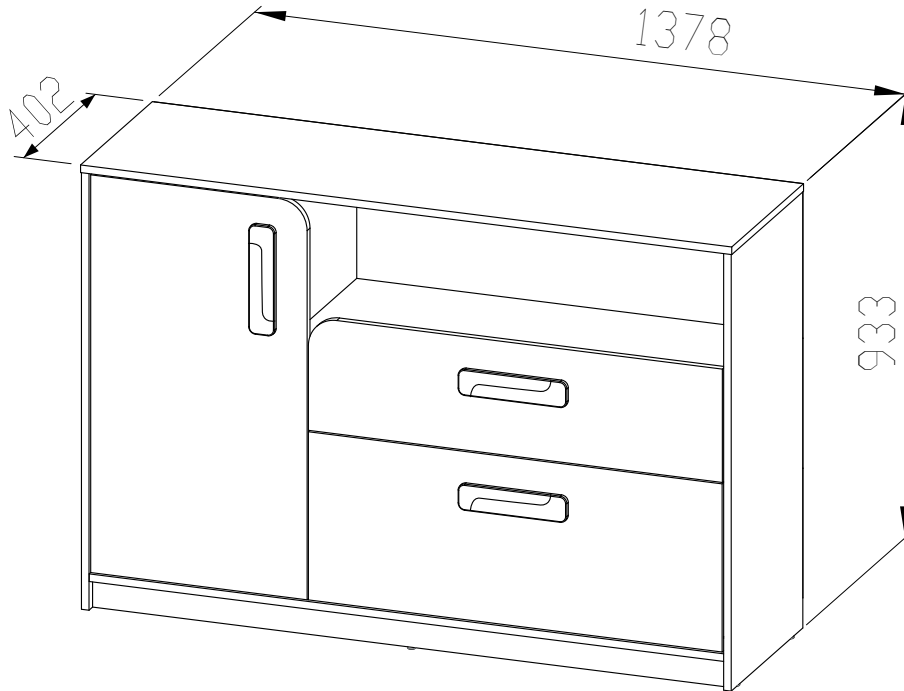
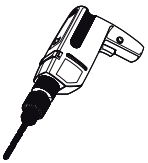
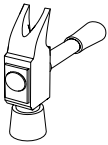
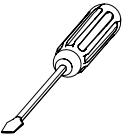
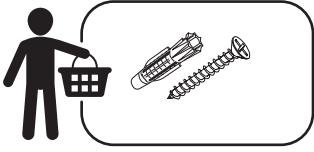
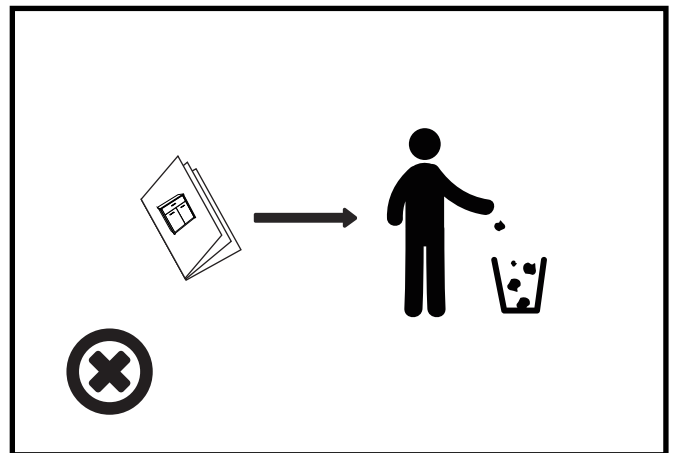
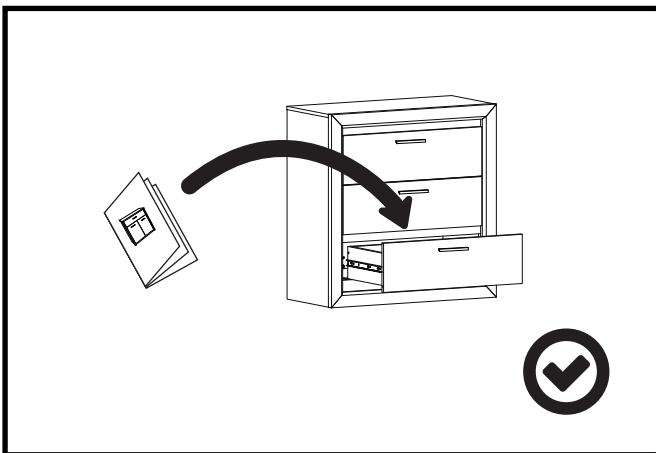
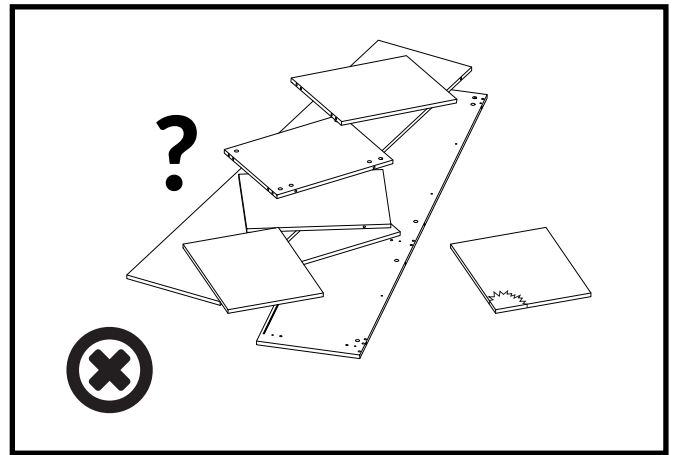
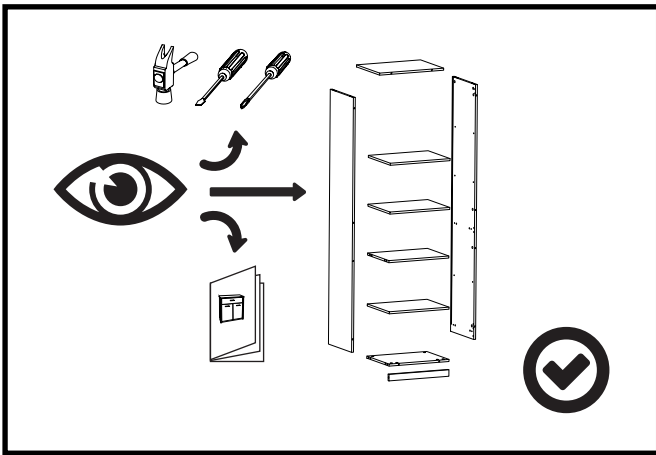
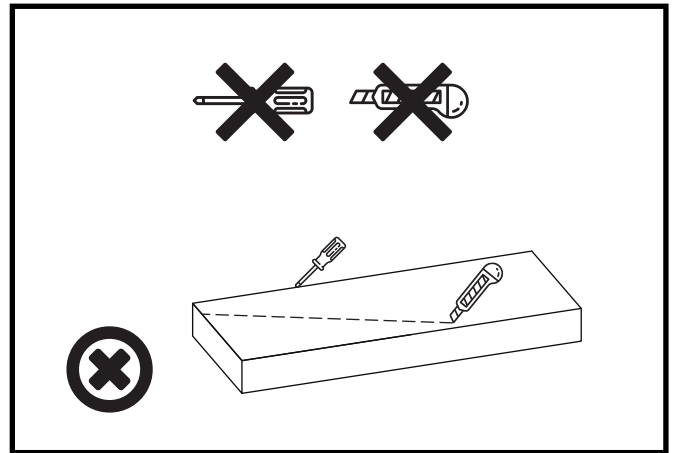
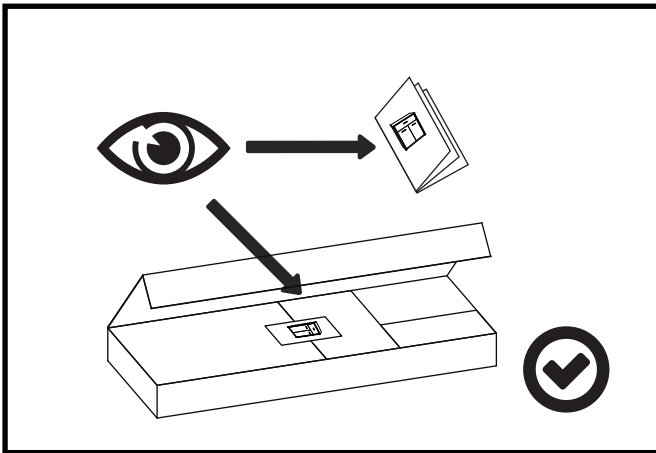
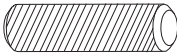

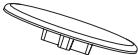
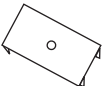

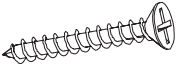

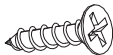
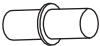
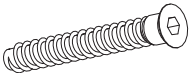
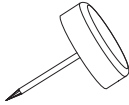
IQ 09

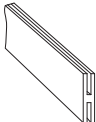

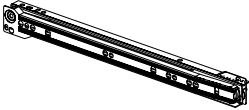

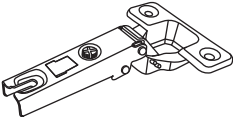
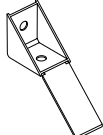

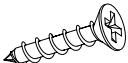
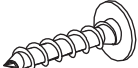

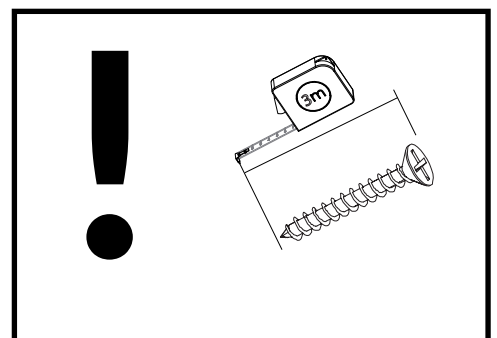

IQ 09

<p>K1 x 30</p> 	<p>GW1 x 50</p> 	<p>B2 x 19</p> 
<p>ZM1 x 14</p> 	<p>BR1 x 6</p> 	<p>ZJ1 x 19</p> 
<p>WT22 x 6 4x35</p> 	<p>WE2 x 4 6,3x13B</p> 	<p>WT1 x 24 3,5x15</p> 
<p>PO2 x 8</p> 	<p>KT1 x 10 6,3x50</p> 	<p>SG1 x 6</p> 
<p>x 1</p> 	<p>LT x 1</p> 	<p>KL x 1</p> 
<p>WS1 x 2</p> 	<p>P5 x 2</p> 	<p>UIQ x 3</p> 
<p>PK4 x 2 H-4</p> 	<p>ZP9 x 2</p> 	<p>PO4 x 2</p> 
<p>SP x 2</p> 	<p>WT35 x 12 3x20</p> 	<p>WT9 x 10</p> 



IQ 09

							
1	220	350	2	12	1343	60	1
2	851	355	2	13	1343	60	1
3	835	458	1	14	524	300	1
4	875,50	353	1	15	928	381	1
5	1373	324	1	16	1343	400	1
6	1373	272	2	17	1378	402	1
7	398	349	2	18	124	350	2
8	841	382	1	19	825	124	1
9	825	220	1	20	876	238	1
10	917	401	1				
11	917	401	1				

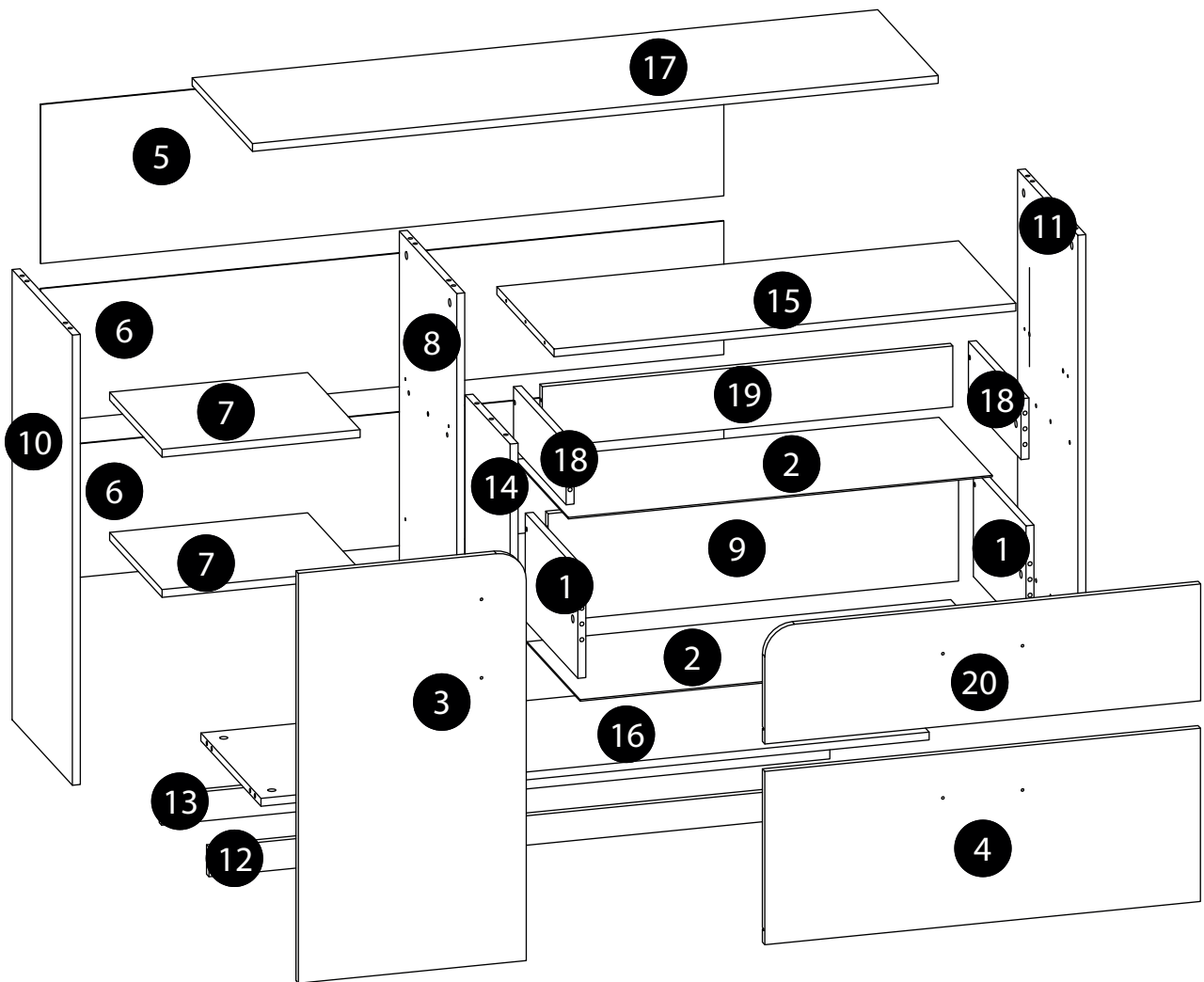

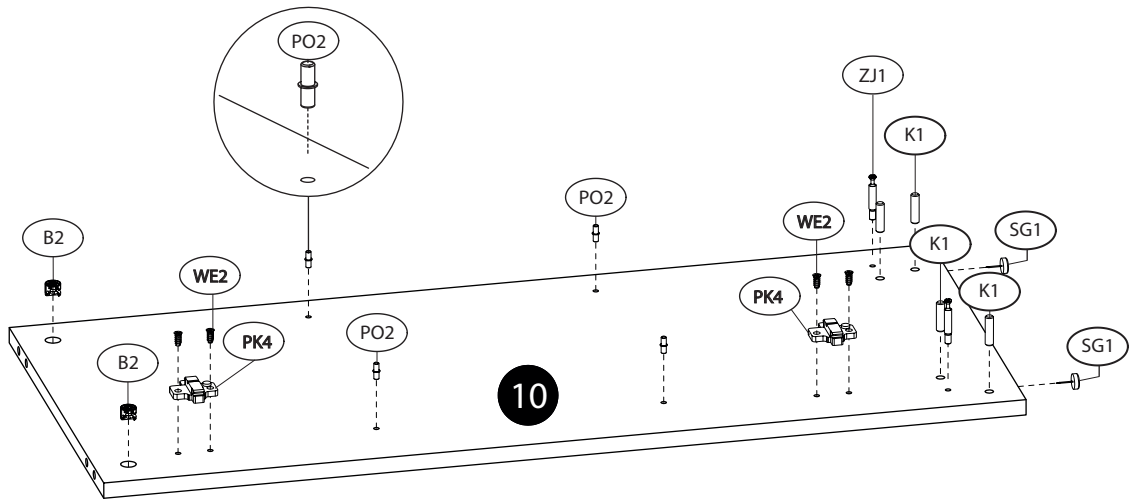
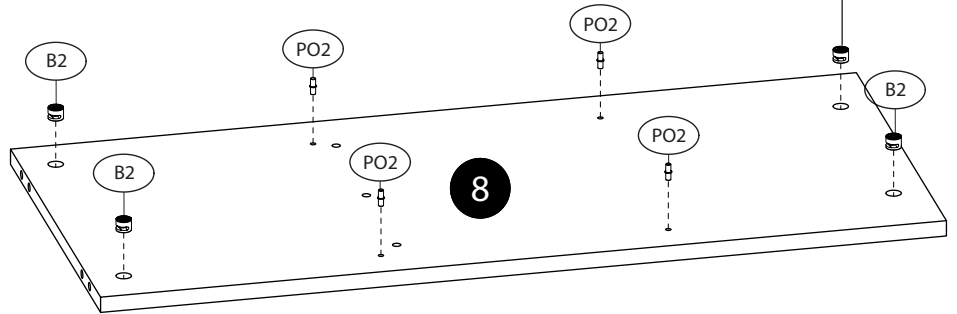
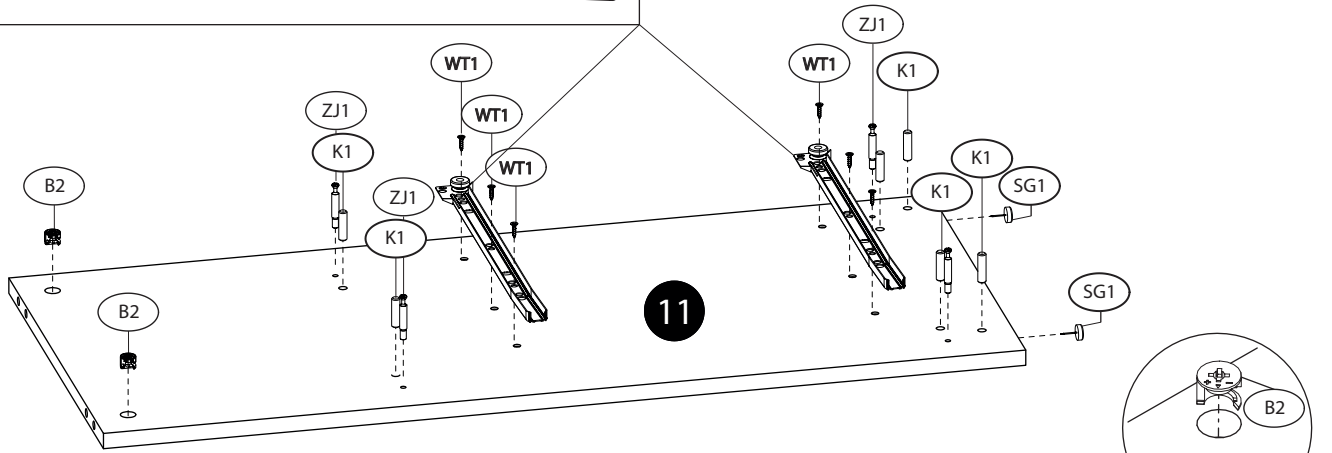
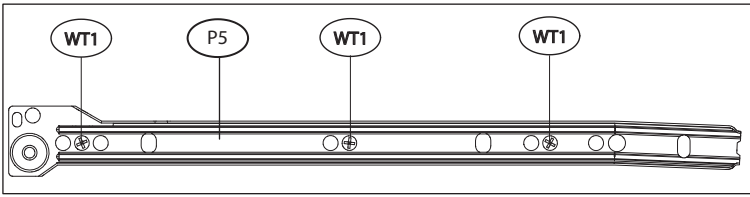
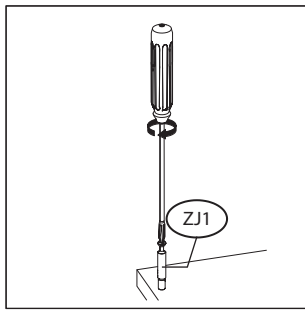
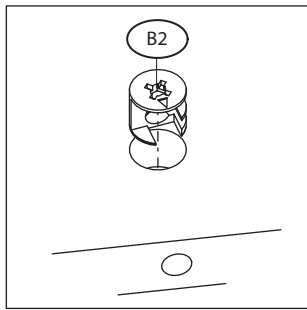
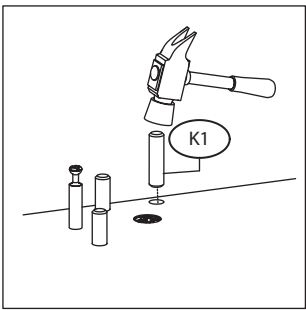

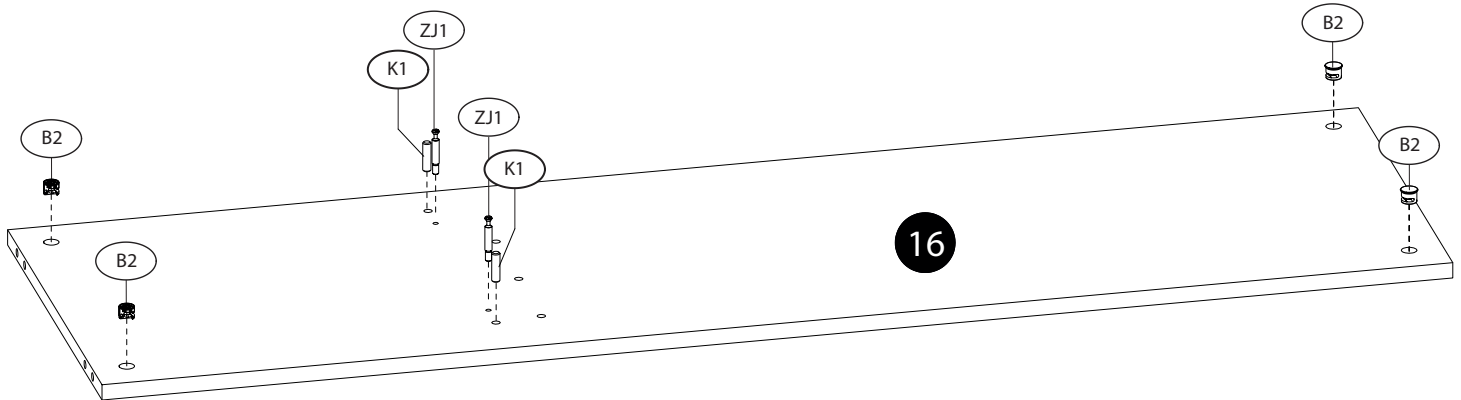
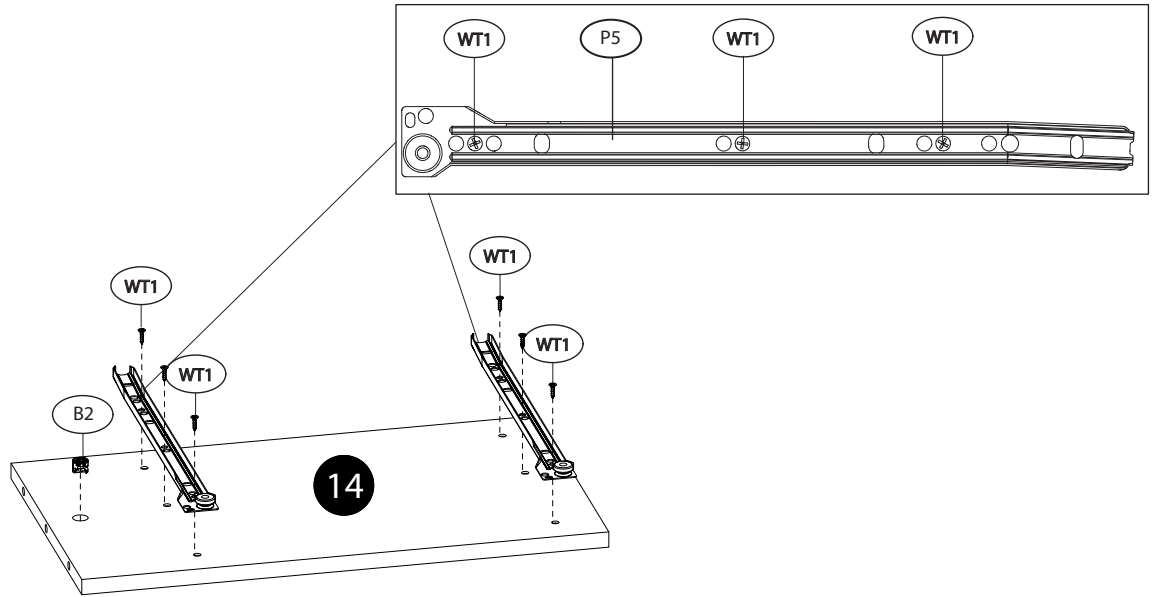
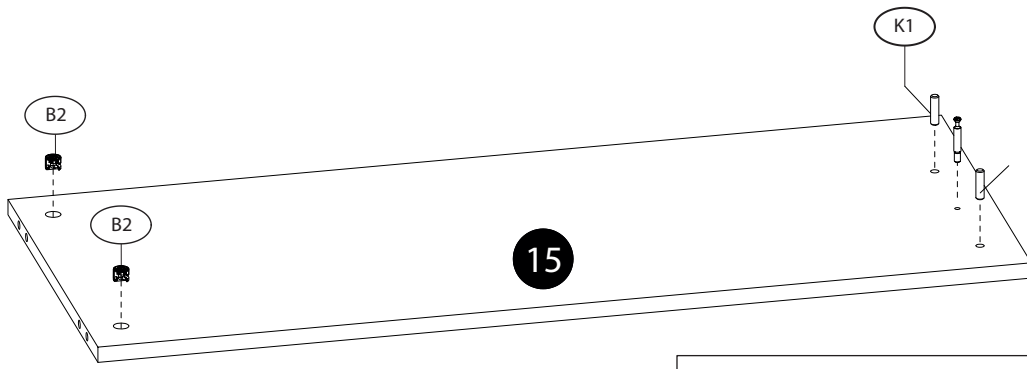

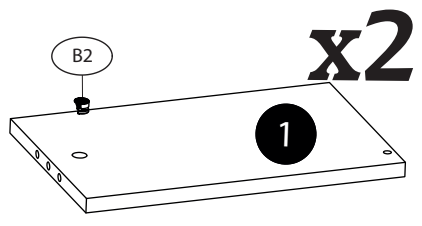
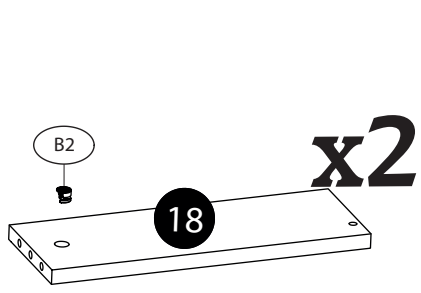
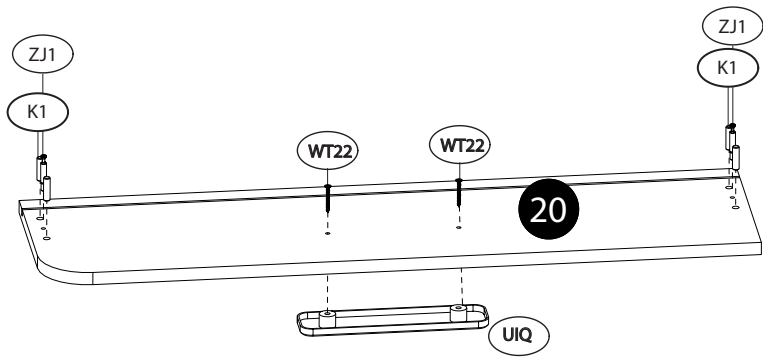
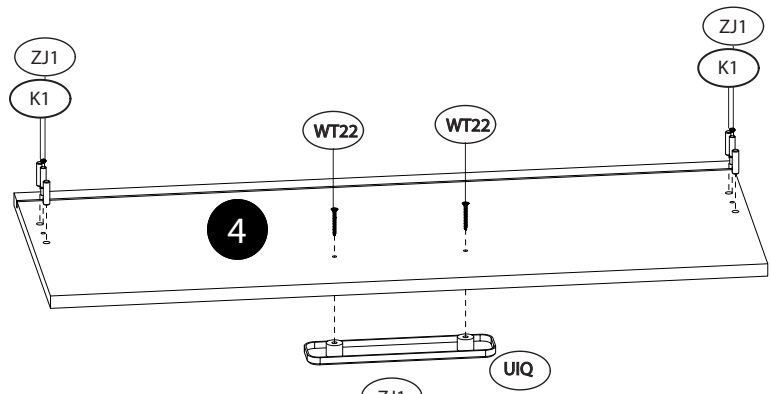
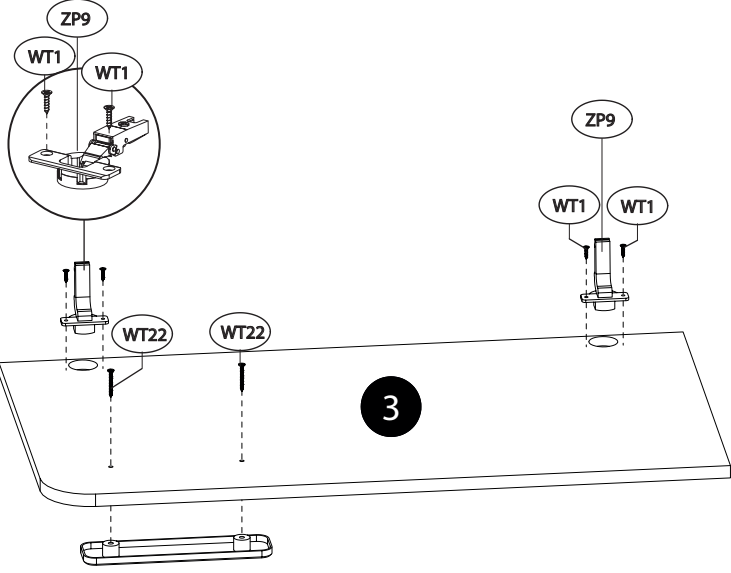
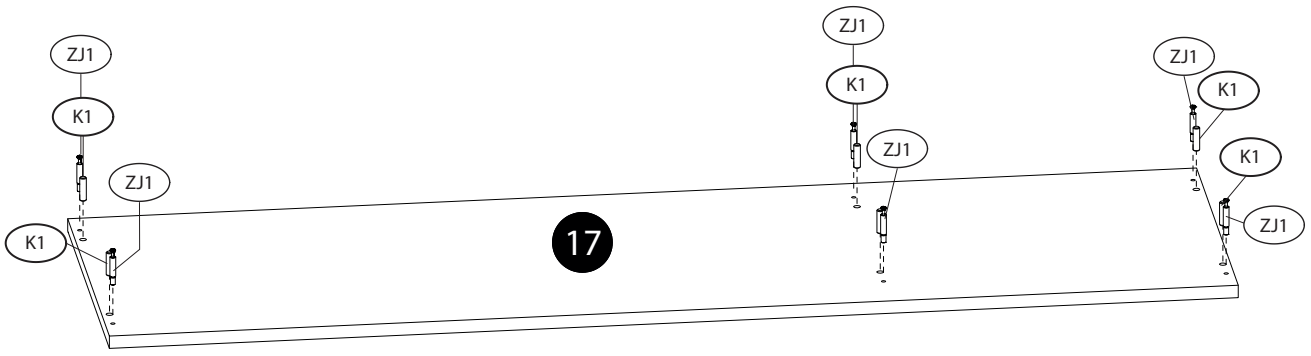

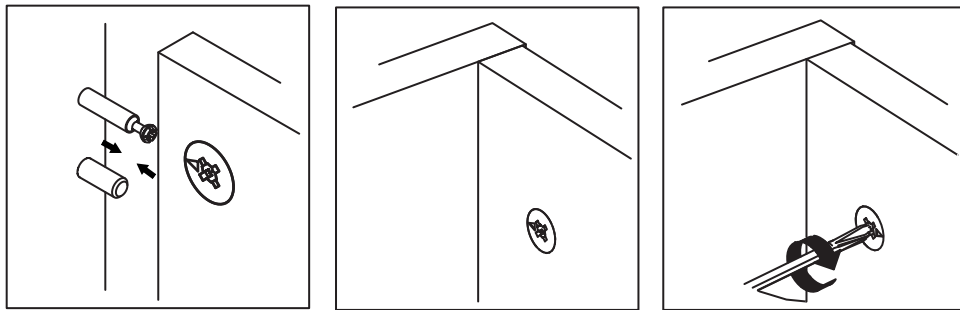

A ▶

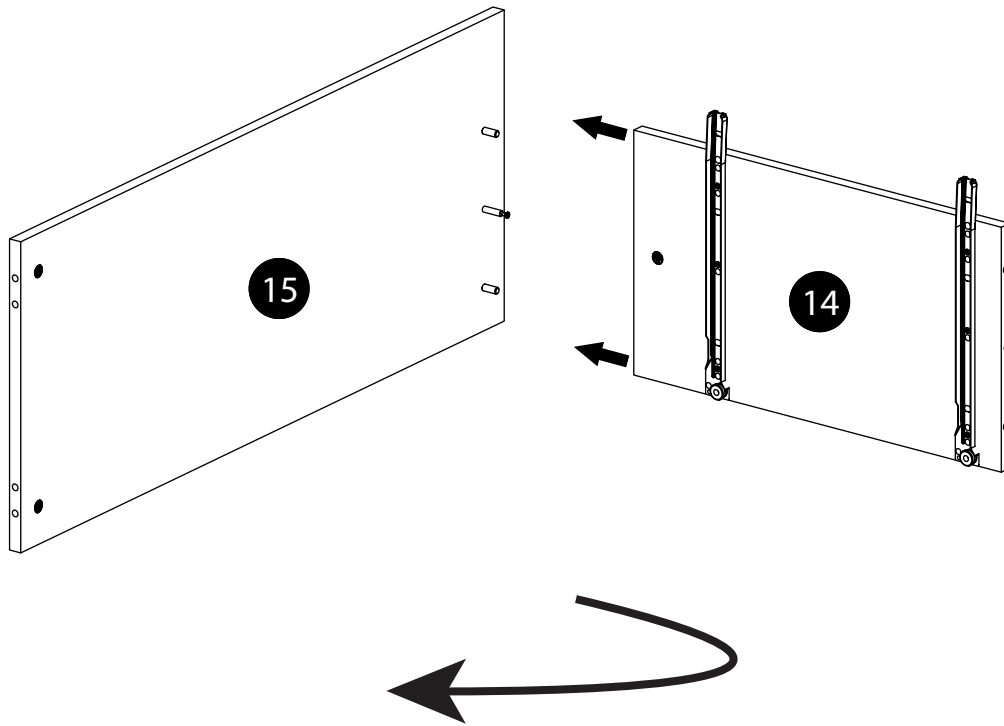

B ▶

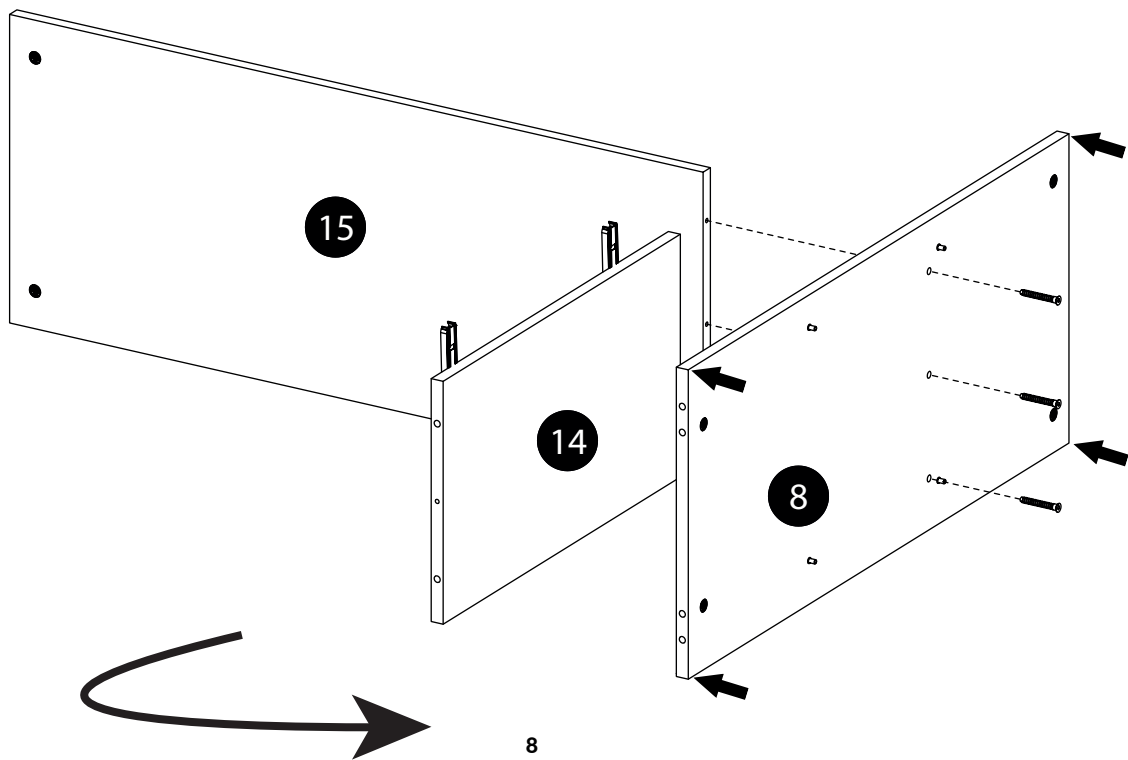

C ▶

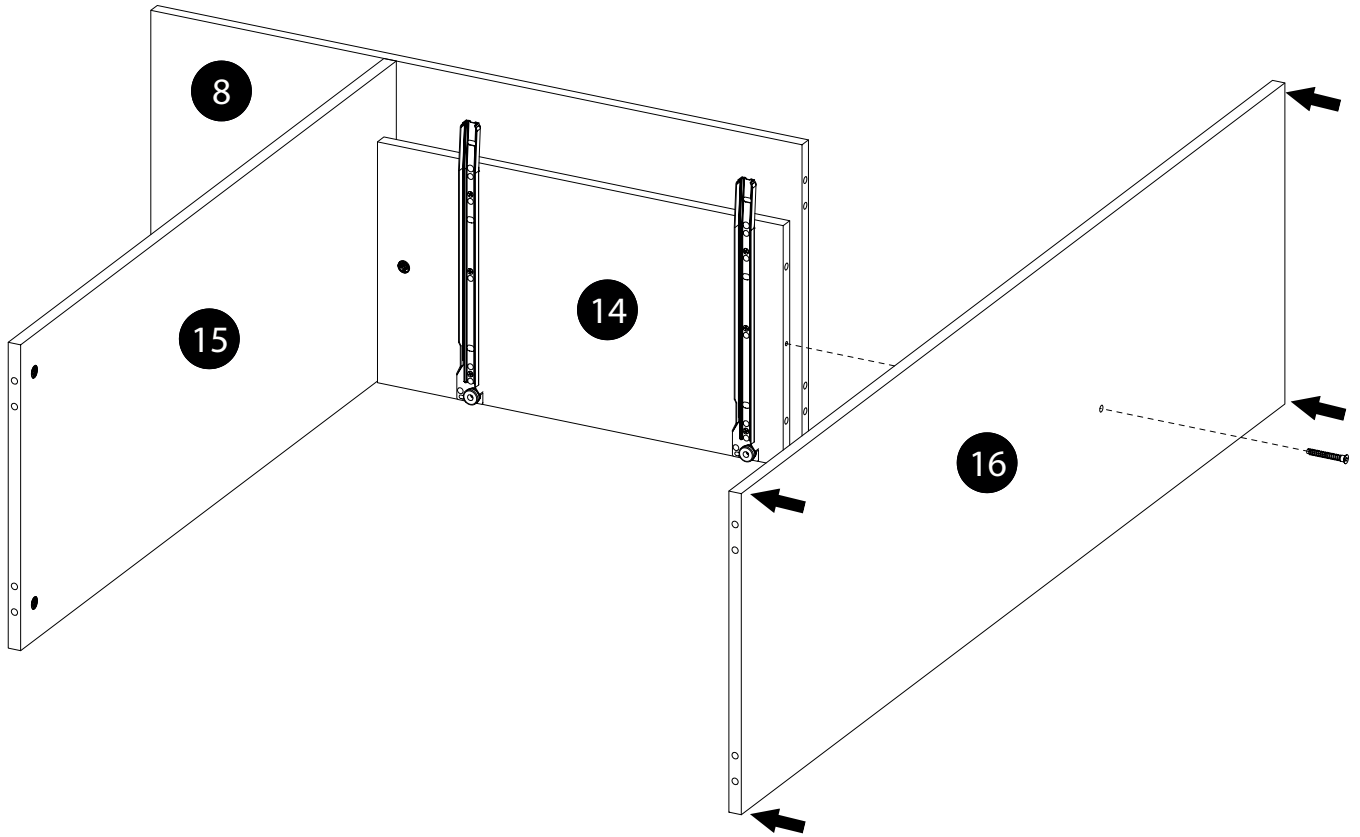

D ▶

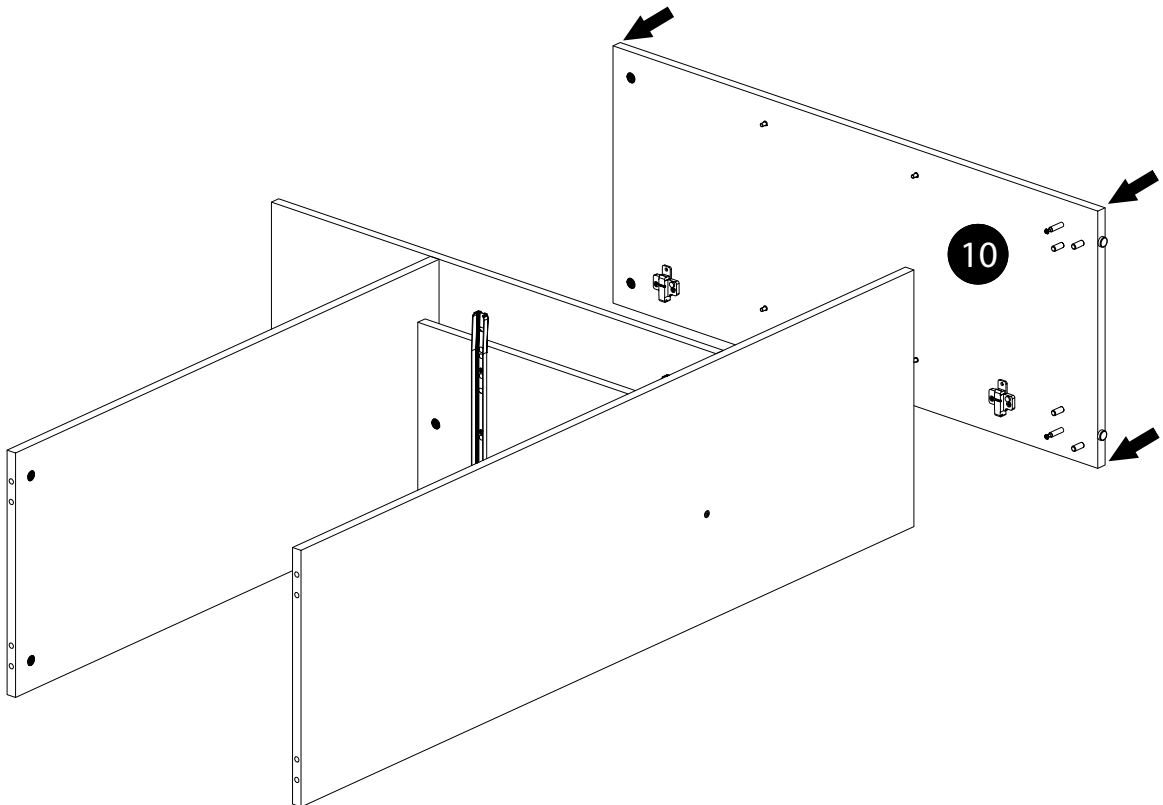

E ▶

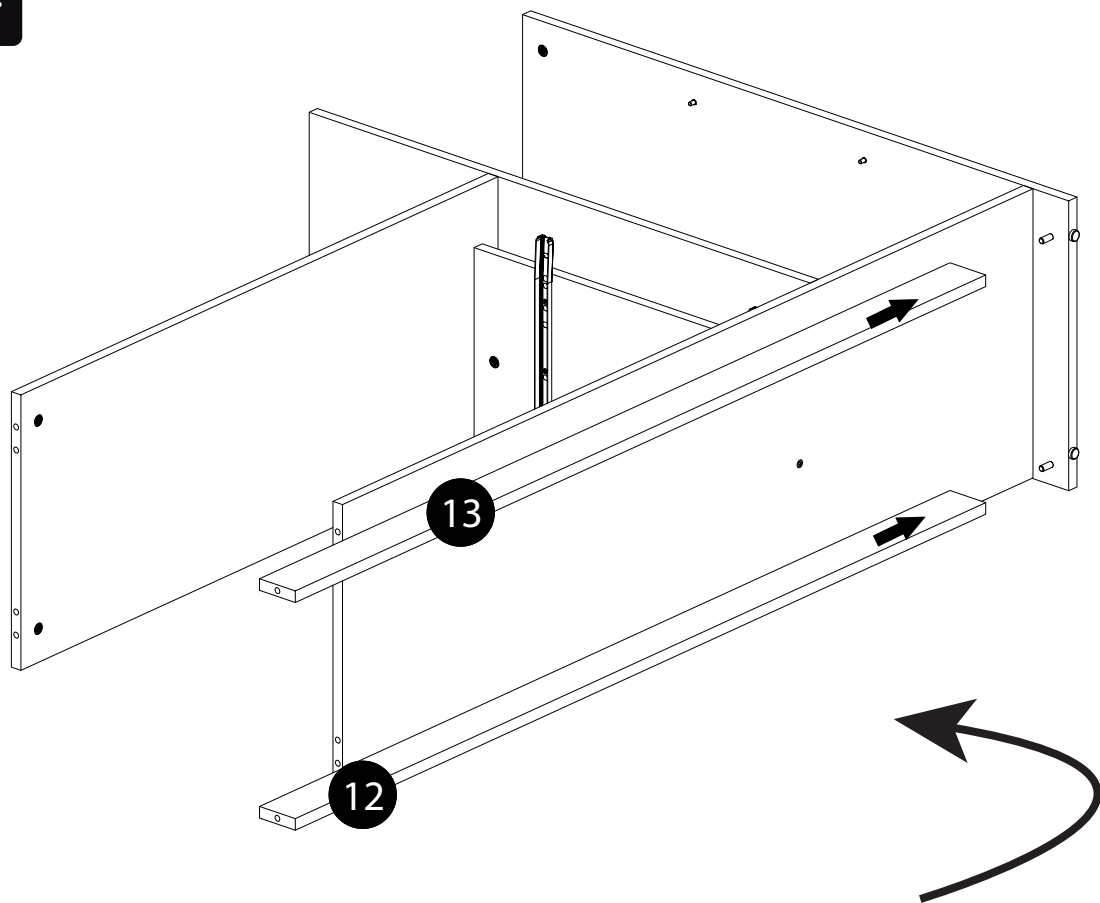

F ▶

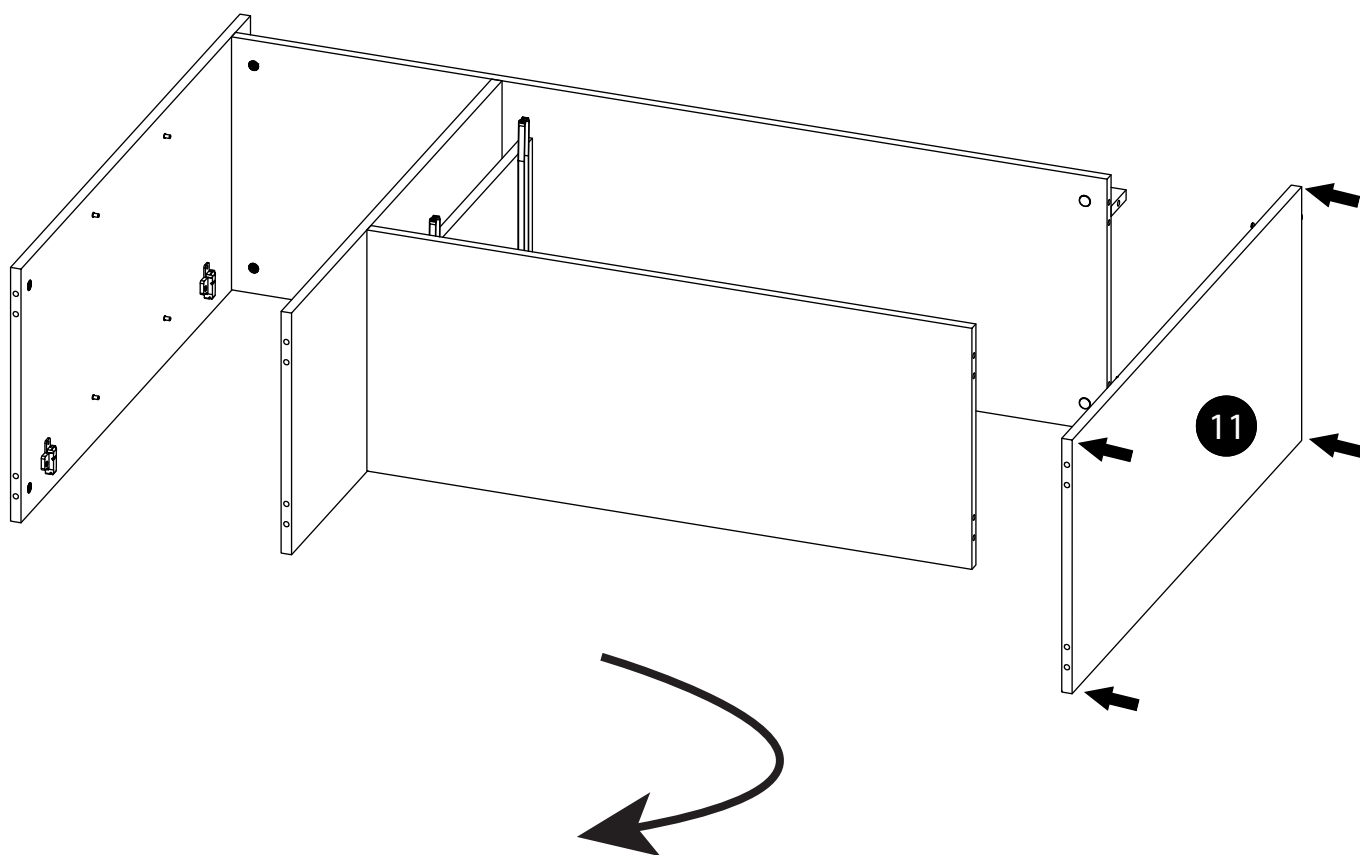

G ▶

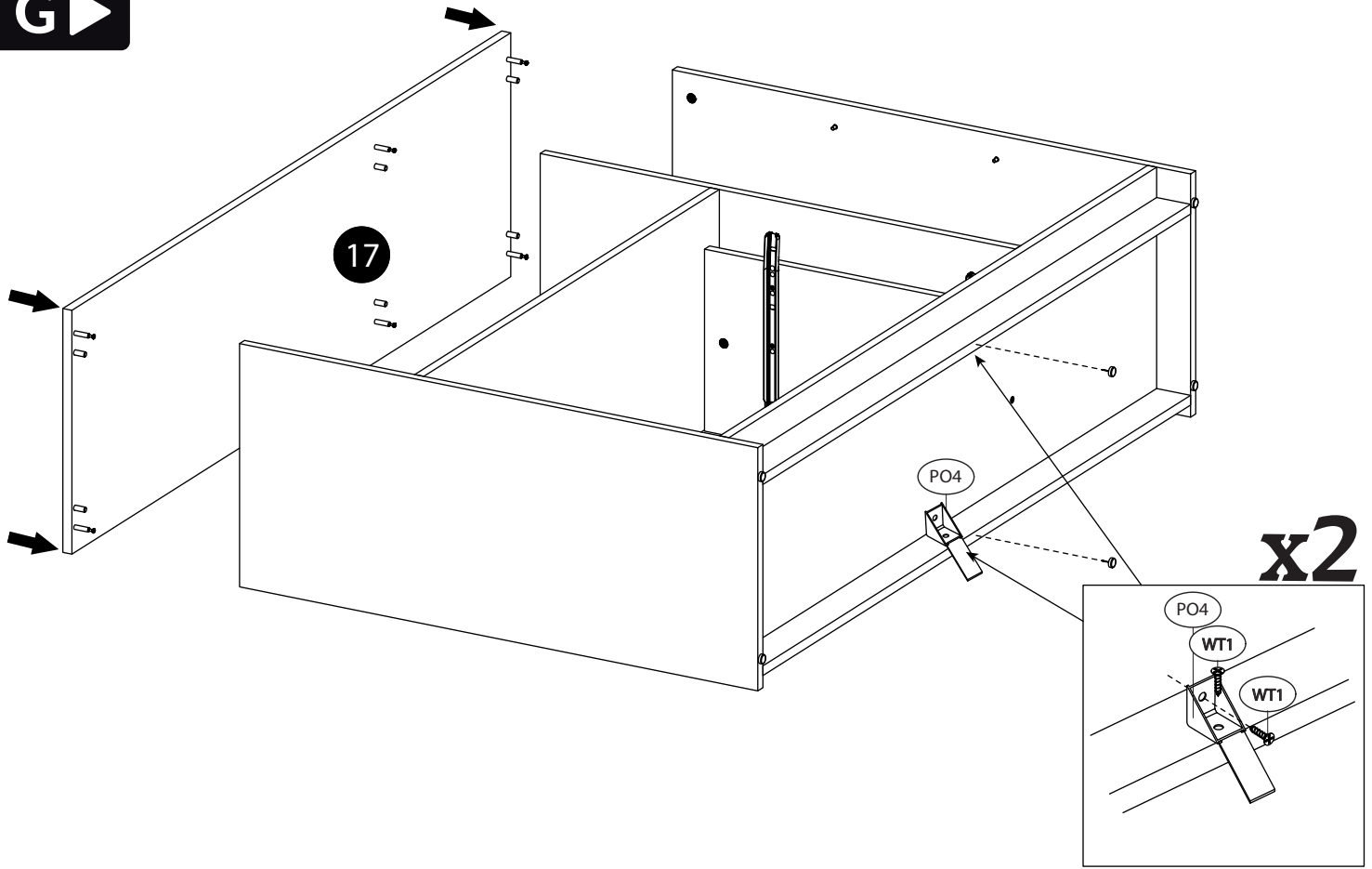

H ▶

