

Modellname: **LAS VEGAS**  
Nazwa modelu:

Modellreihe: **37 -- LV**  
Numer modelu:

Type: **02**  
Typ:

Blatt Nr **1** von: **8**  
Strona **1** z:

### Pflegehinweis!

Bitte nur mit einem Staubtuch  
oder einem feuchten Lappen reinigen.  
**KEINE** scheuernde  
Putzmittel verwenden !

### Wskazówka dotycząca pielęgnacji!

Proszę czyścić tylko suchą  
lub lekko wilgotną szmatką do kurzu.  
Nie używać żadnych środków szorstkich !

## MONTAGEANLEITUNG INSTRUKCJA MONTAŻOWA

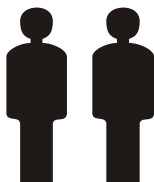

**2 Personen**  
**2 Osoby**

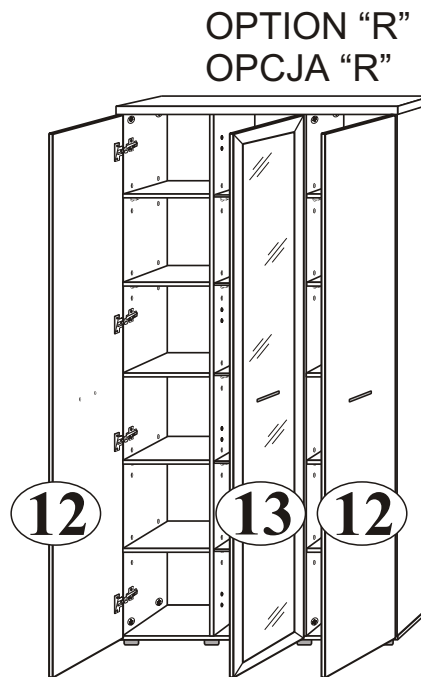
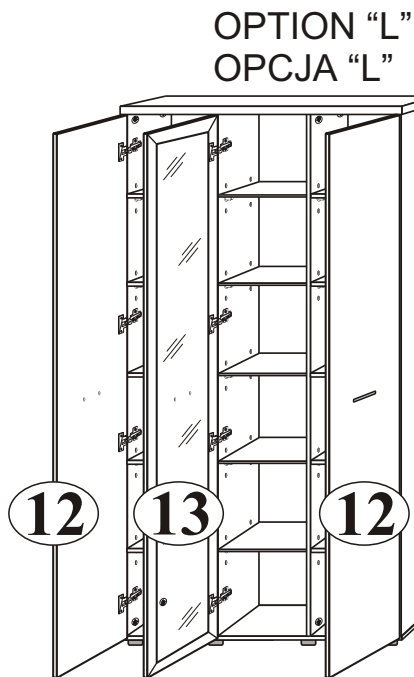
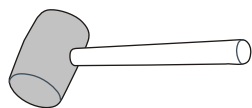
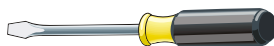
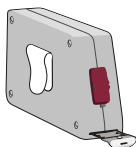

Max. zulässige Belastungen  
von Einlegeböden in kg:

Maksymalne obciążenie półek w kg:

Stärke/Gr. Länge/Dł. mm	Spanplatte/Płyta		Glas/Szkło
	15	18	22
0<400			5/6
401<600	40	40	40
601<800	24		
801<1000	15	30	

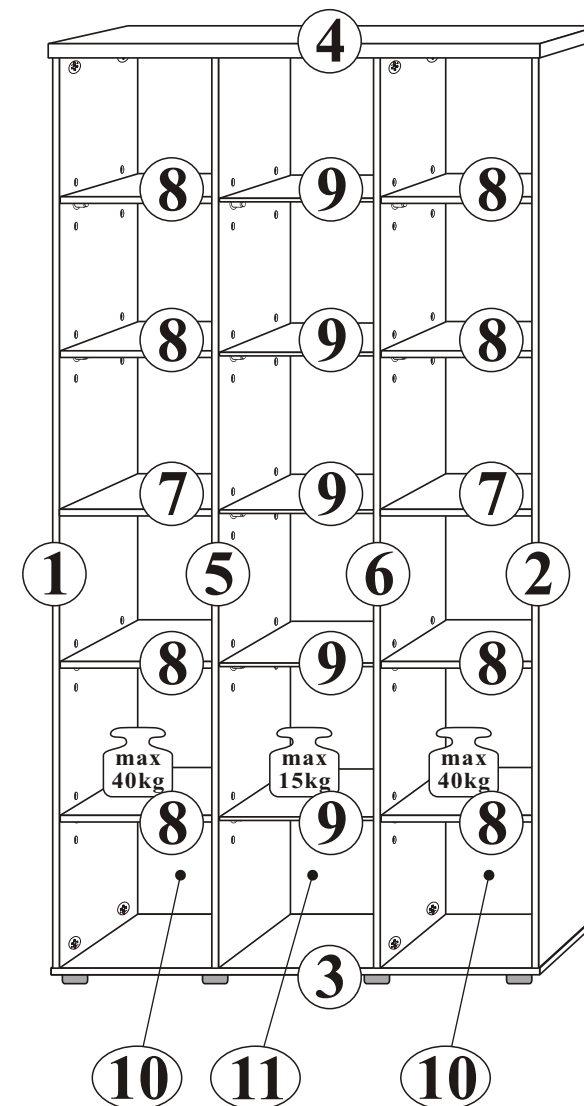



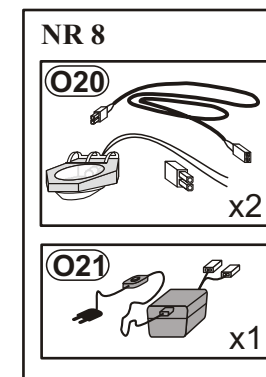
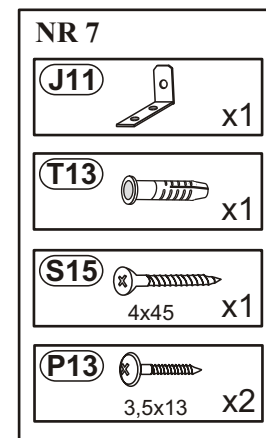
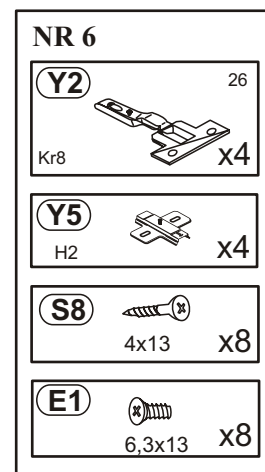
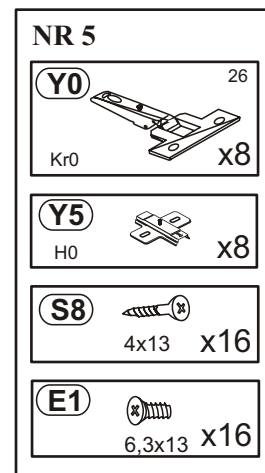
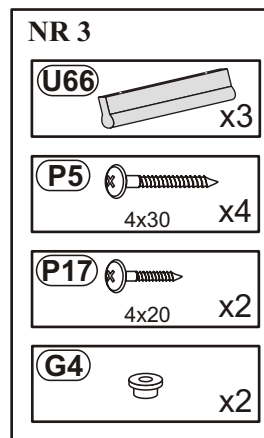
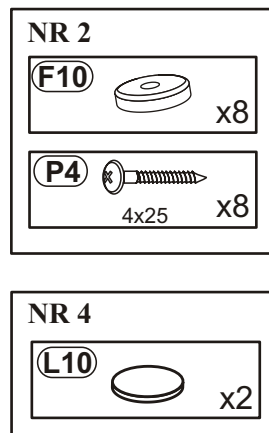
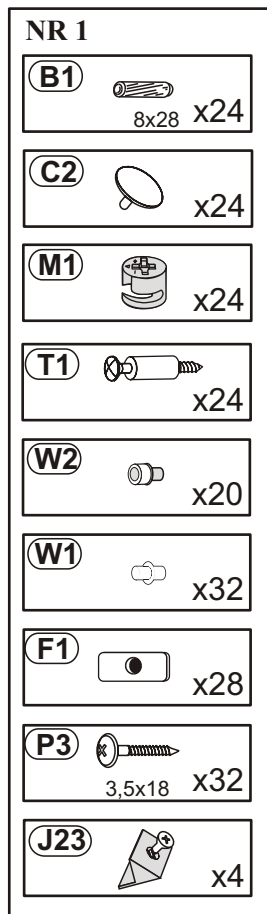

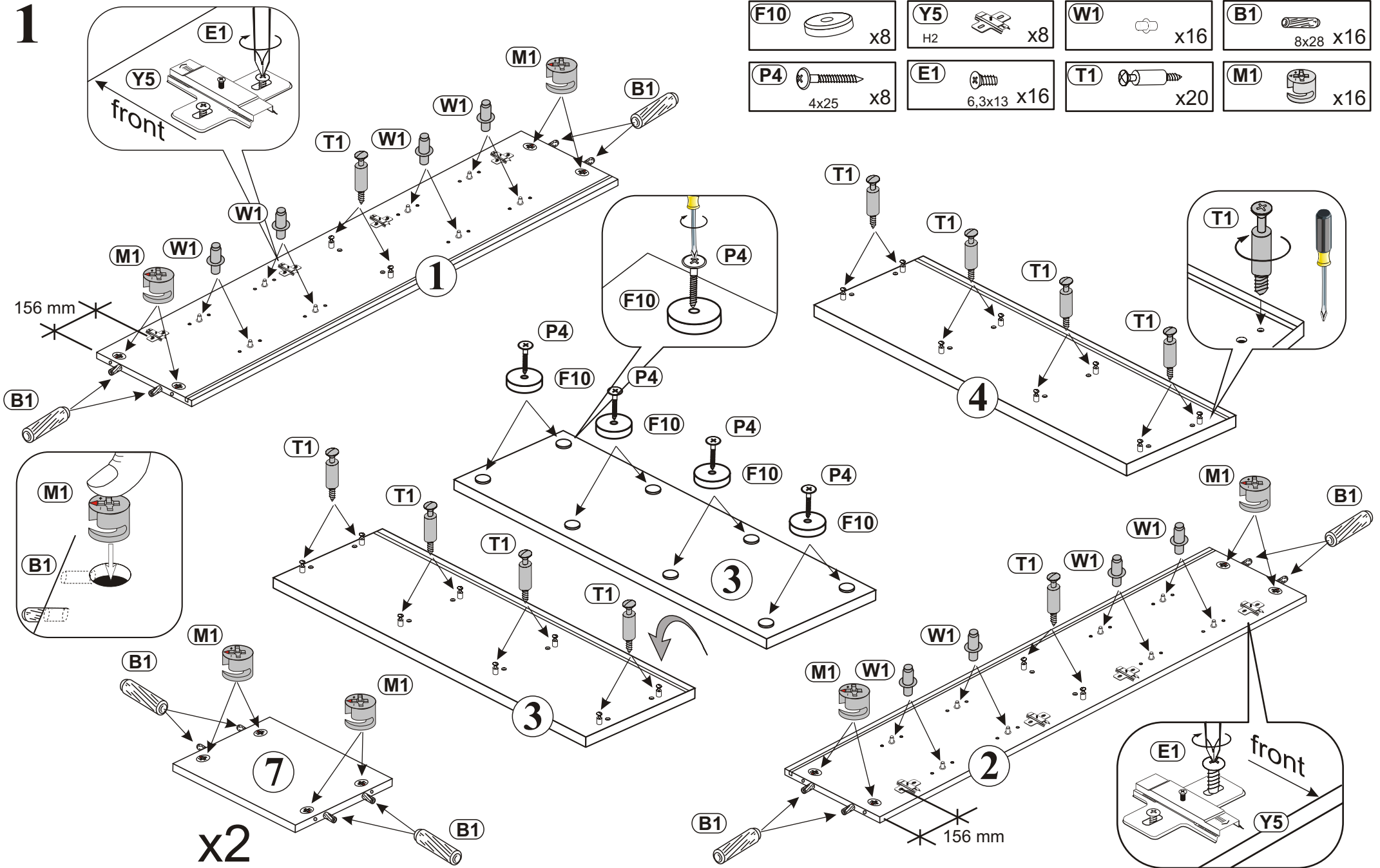

## BESCHLAGLISTE WYKAZ OKUĆ



**1**



**2**

<b>Y5</b> H2  x4	<b>W1</b>  x16	<b>B1</b> 8x28  x8
<b>E1</b>  6,3x13 x8	<b>W2</b>  x20	<b>M1</b>  x8
<b>T1</b>  x4		

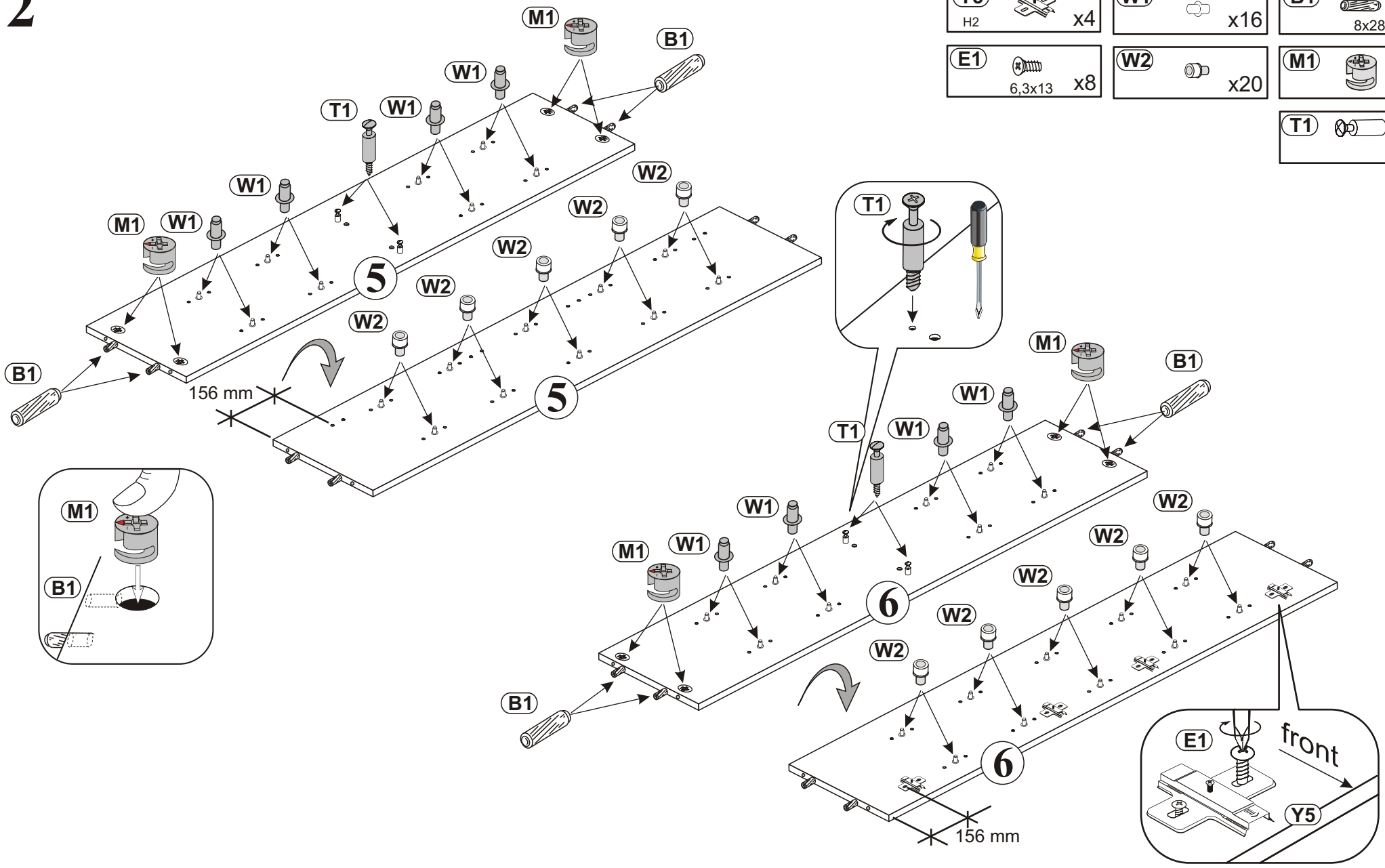

**3**

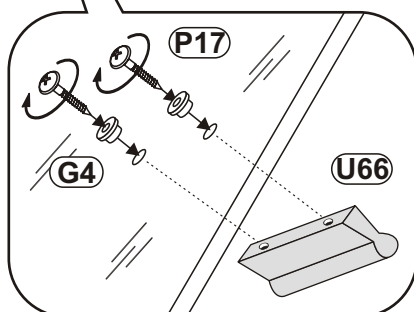
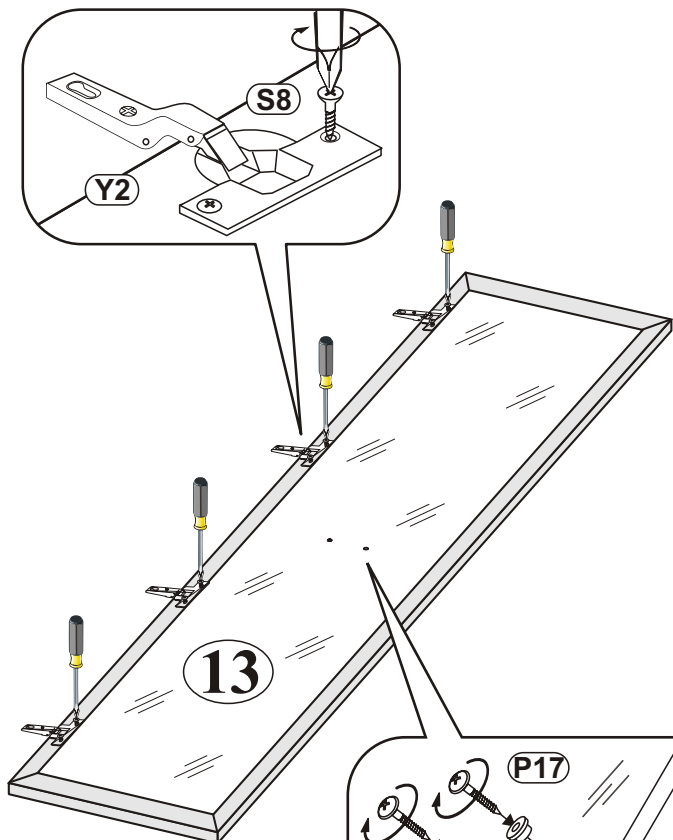
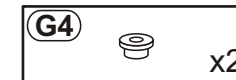
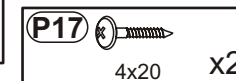
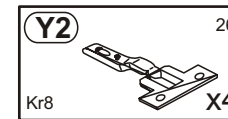
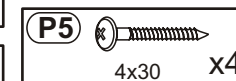
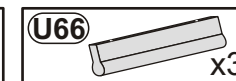
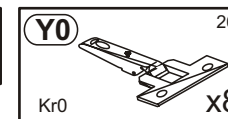
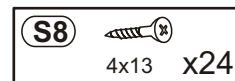

ACHTUNG!  
 VORSICHTIG  
 ANSCHRAUBEN  
 MIT EINEM  
 HANDSCHRAUBENDREHER.

UWAGA!  
 DELIKATNIE PRZYKRĘCAĆ  
 RĘCZNYM WKRĘTAKIEM.

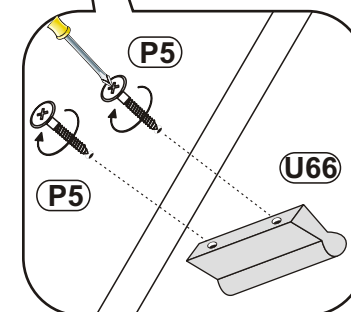
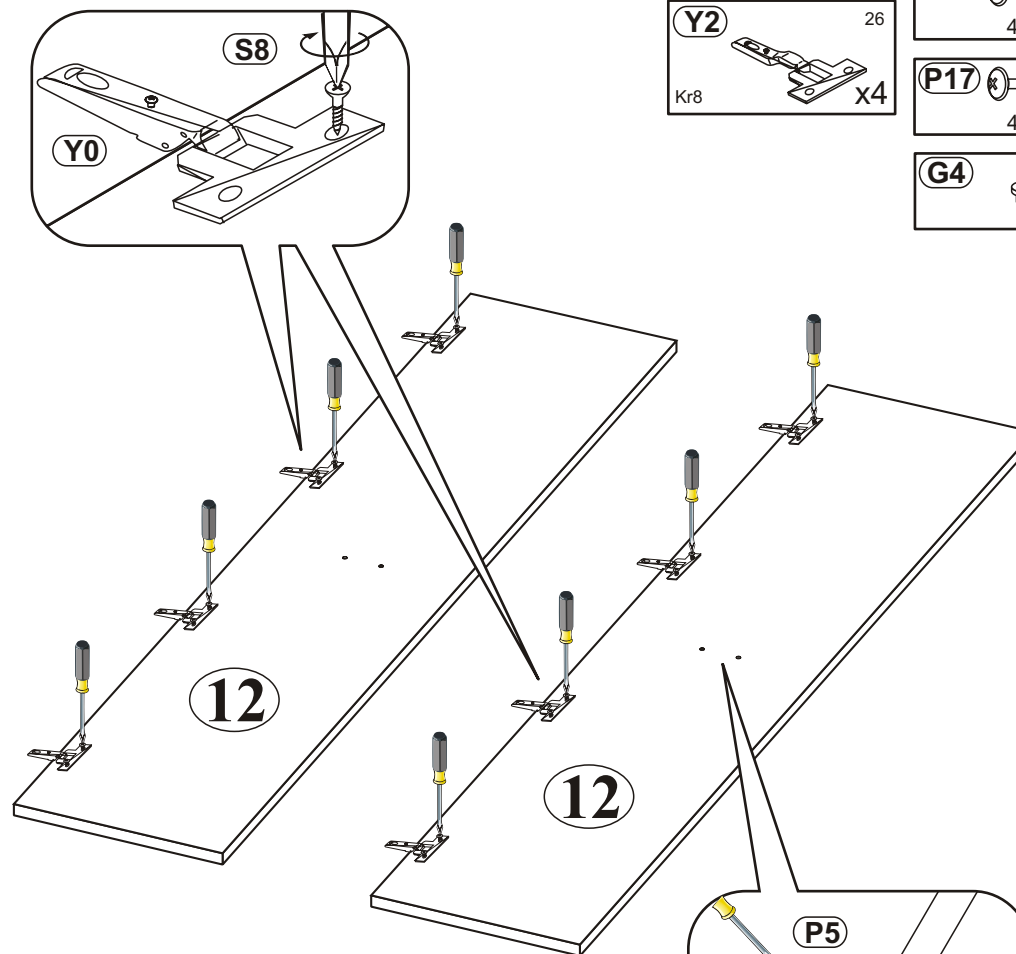
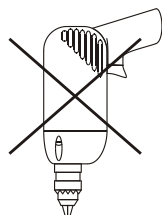

Modellname: **LAS VEGAS**  
Nazwa modelu:

Modellreihe: **37 -- LV**  
Numer modelu:

Type: **02**  
Typ:

Blatt Nr **6** von: **8**  
Strona z:

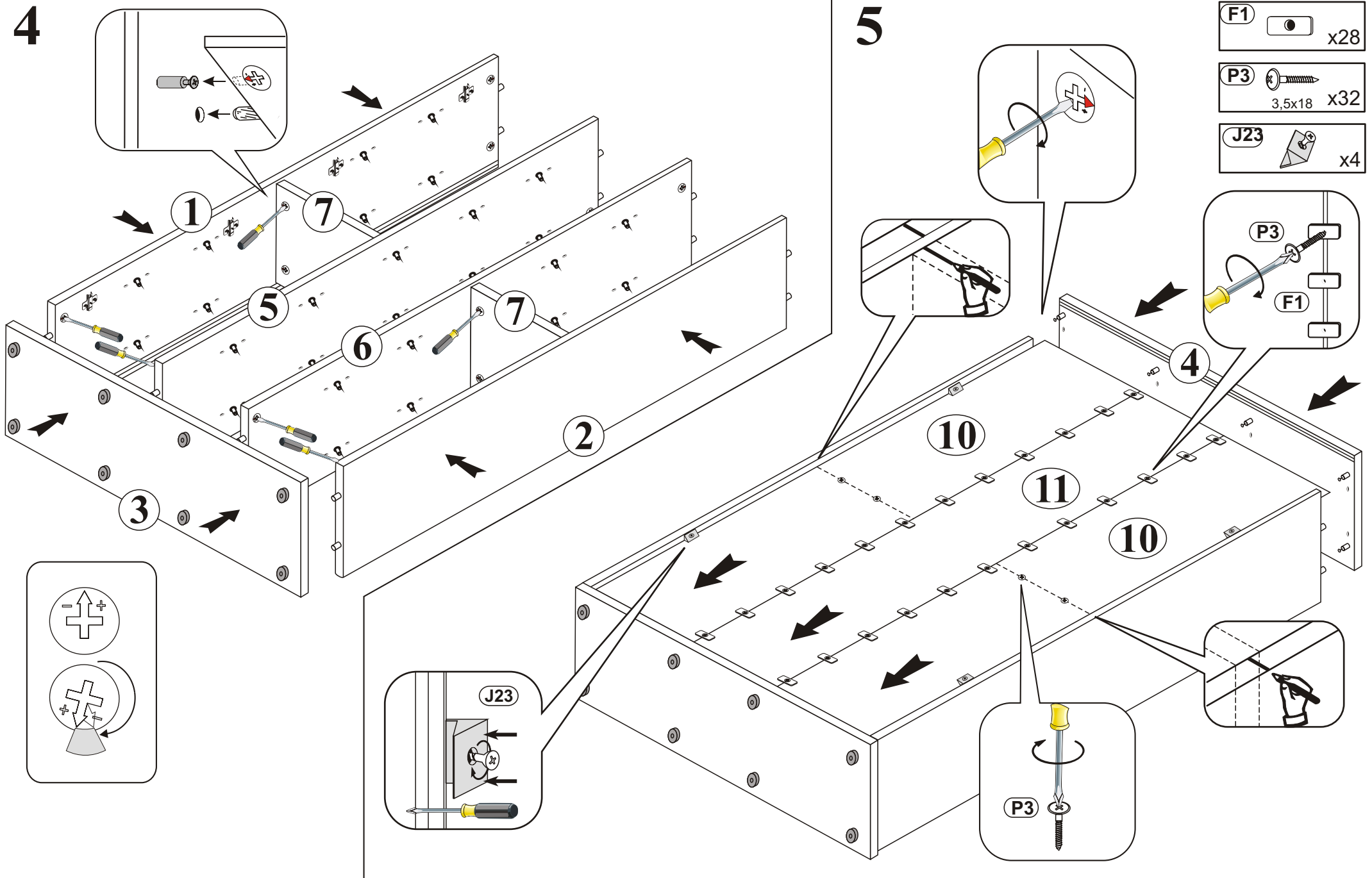

**6**

OPTION "L"  
OPCJA "L"



OPTION "R"  
OPCJA "R"

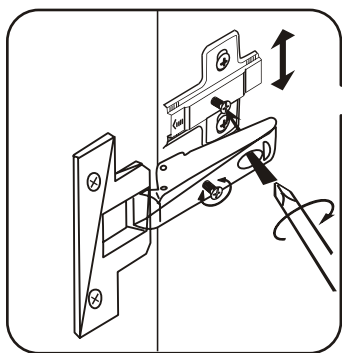
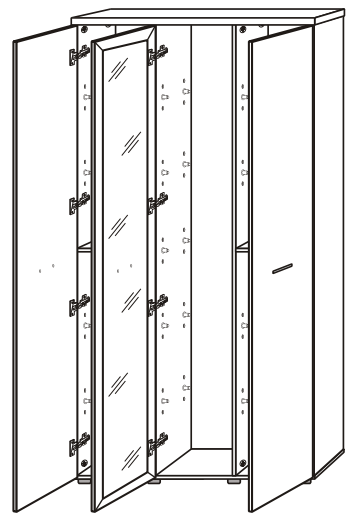

**12**

**13**

**12**

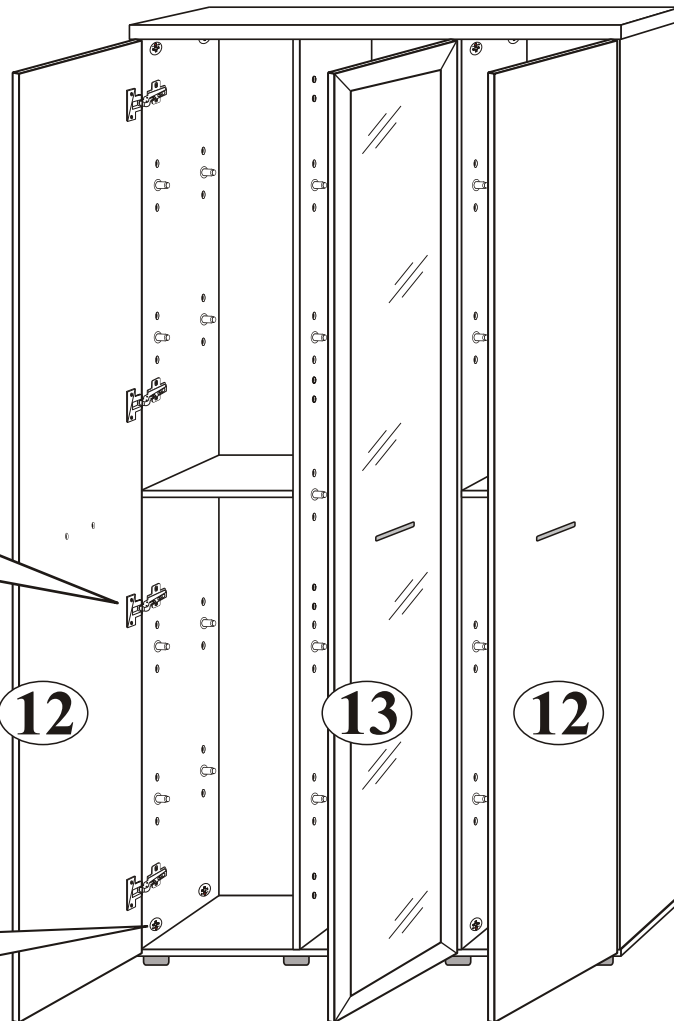
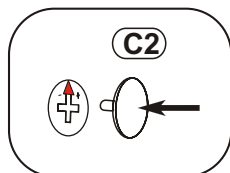

**7**

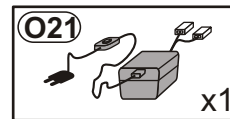
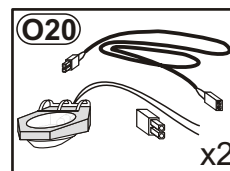

Kabel nach hinten führen

Kabel einrasten und Stecker schließen

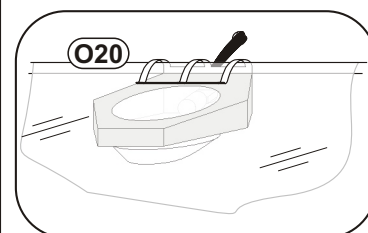

**8**

**8**

**9**

**8**

**8**

**9**

Anschluß für  
Zubehörtype - Trafo

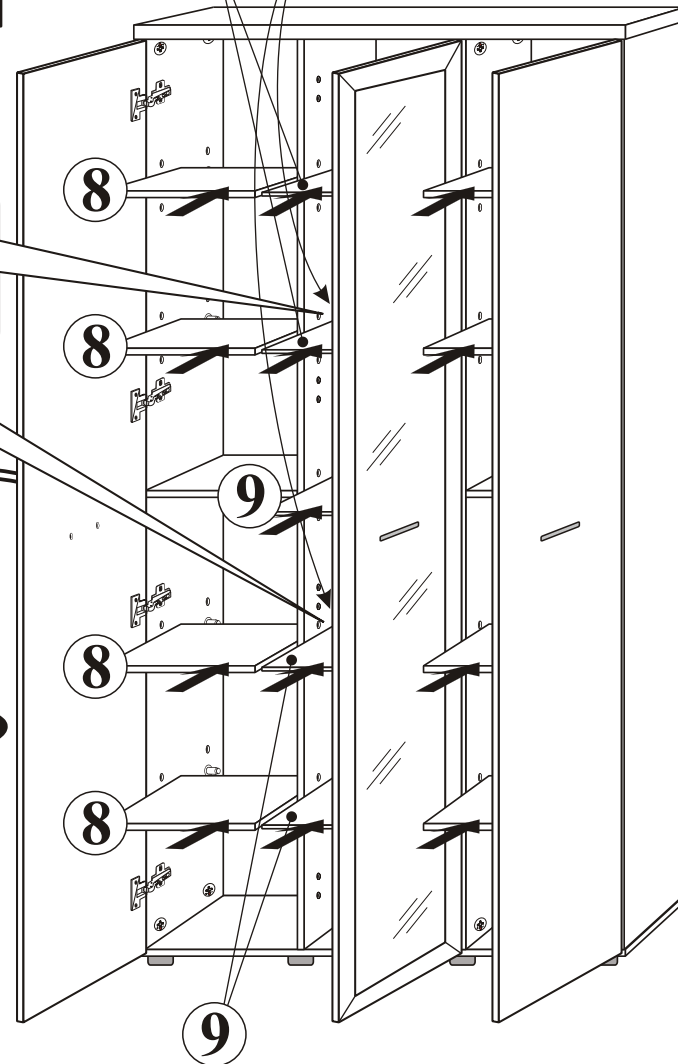

8

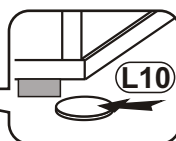
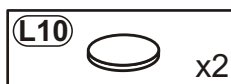
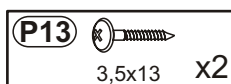
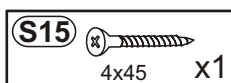
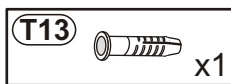
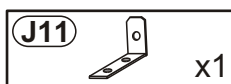
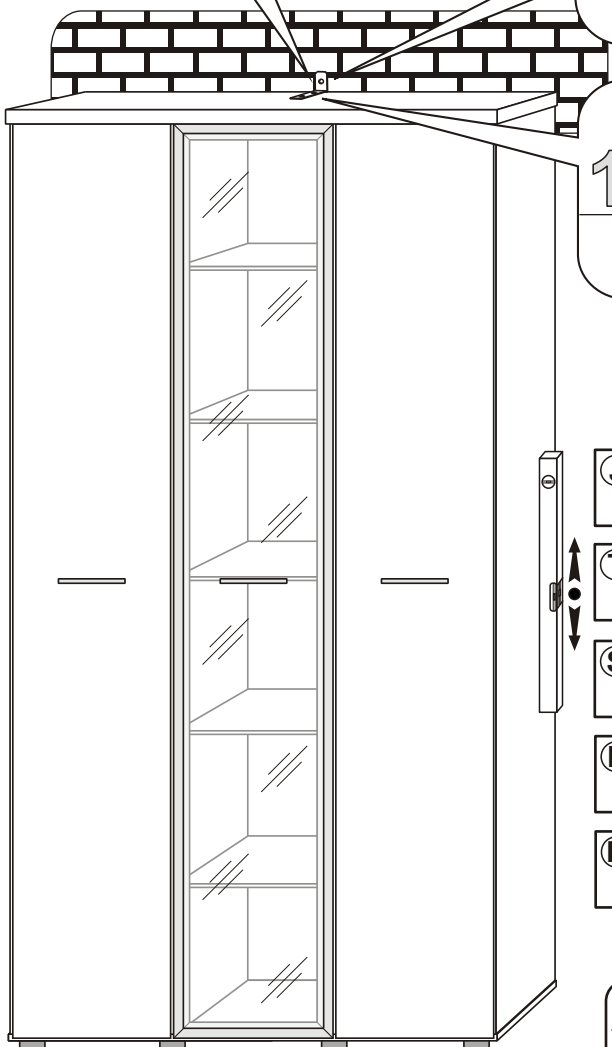
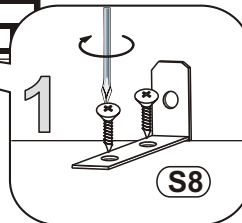
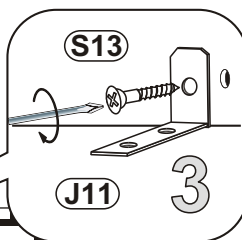
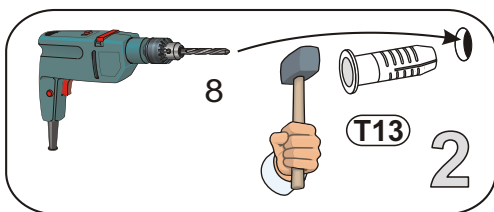

Załączone kołki do zawieszania bryły, do stosowania wyłącznie do ścian betonowych, do innych ścian należy odpowiednio dokupić.

PL

Die beigefügten Dübel zum Aufhängen des Elements dürfen nur bei Betonwänden eingesetzt werden, bei anderen Wandarten müssen entsprechende Dübel zugekauft werden.

D

### Verstellmöglichkeiten

- a) Fugenverstellung: Befestigungsschraube "A" lockern, gewünschte Fuge mit Schraube "B" einstellen, Schraube "A" anziehen.
- b) Tiefenverstellung: Befestigungsschraube "A" lockern, Bandarm nach vorne oder rückwärts verschieben, Schraube "A" anziehen, Schraube "B" mit einer 1/4 Drehung nach rechts arretieren.
- c) Höhenverstellung: Befestigungsschraube "C" lockern, Höhe einstellen, Schraube "C" anziehen.

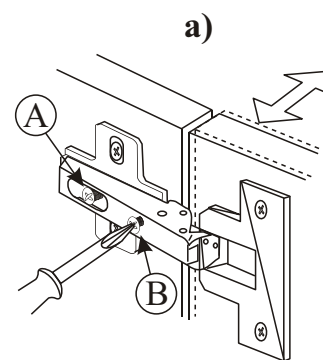

### Instructions for hinge adjustment

- a) Side adjustment: Loosen fixing screw "A", adjust gap with screw "B" and retighten screw "A".
- b) Depth adjustment: Loosen fixing screw "A", push hinge arm forwards or backwards, retighten screw "A", fix screw "B" with a 1/4-turn in clock-wise direction.
- c) Height adjustment: Loosen screw "C", adjust height, retighten screw "C".

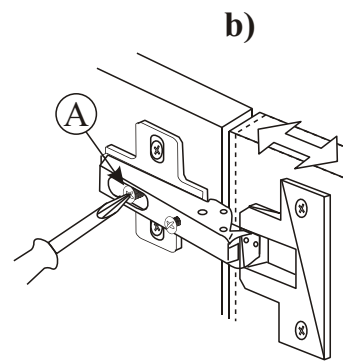

### Les possibilités de positionnement

- a) Positionnement de la rainure: Desserrer la vis de fixation "A", positionner avec la vis "B" la rainure (joint) souhaitée et resserrer la vis "A".
- b) Positionnement de la profondeur: Desserrer la vis de fixation "A" (1 tour), régler la profondeur et resserrer la vis "A".
- c) Positionnement de la hauteur: Desserrer la vis de fixation "C" (1 tour), positionner la hauteur et resserrer la vis "C".

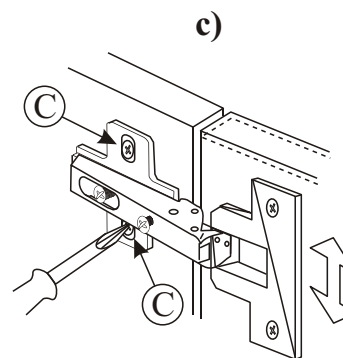

### Możliwości regulacji

- a) Regulacja szczeliny: Poluzować wkręt "A", wkrętem "B" ustawić odpowiednią szczelinę, dokręcić wkręt "A".
- b) Regulacja głębokości: Poluzować wkręt "A" (1 obrót), ustawić głębokość, dokręcić wkręt "A".
- c) Regulacja wysokości: Poluzować wkręt "C" (1 obrót), dokonać regulacji wysokości położenia drzwi, wkręt "C" dokręcić.



